

**Polished, Heli/Wire Arc Welded Carts**

**Stem Caster Type**



Model 2010-5

**Plate Caster Type**



Model 2035

**500 Pounds Capacity:**

- **Legs:** 14 GA. S/S
- **Casters:** 5" all swivel.

- **Shelves:** 20 GA. S/S
- **Bumper:** Legs & handle.



Shelf Size	Stem Caster Type			Plate Caster Type			O.A. Dimension		Approx. Wt. (Lbs.)
	Model No.	Shelf Clearance (Inch)	Height (Inches)	Model No.	Shelf Clearance (Inch)	Height (Inch)	Width	Length	
16" x 24"	2010-5	11	35 <sup>3</sup> / <sub>4</sub>	2010	12 <sup>1</sup> / <sub>4</sub>	36 <sup>3</sup> / <sub>16</sub>	17	28	42
18" x 27"	2011-5	11	35 <sup>3</sup> / <sub>4</sub>	2011	12 <sup>1</sup> / <sub>4</sub>	36 <sup>3</sup> / <sub>16</sub>	19	31	54
23" x 34"	2012-5	11	35 <sup>3</sup> / <sub>4</sub>	2012	12 <sup>1</sup> / <sub>4</sub>	36 <sup>3</sup> / <sub>16</sub>	24	38	72

**650 Pounds Capacity: (Heavy Duty, Deluxe)**

- **Legs:** 14 GA. S/S.
- **Casters:** 5" x 1<sup>1</sup>/<sub>4</sub>" deluxe, all swivel.

- **Shelves:** 18 GA. S/S.
- **Bumpers:** Legs & handles.

Shelf Size	Stem Caster Type			Plate Caster Type			O.A. Dimension		Approx. Wt. (Lbs.)
	Model No.	Shelf Clearance (Inch)	Height (Inches)	Model No.	Shelf Clearance (Inch)	Height (Inches)	Width	Length	
16" x 24"	2035-5	11	36	2035	12 <sup>1</sup> / <sub>4</sub>	36 <sup>3</sup> / <sub>16</sub>	17	28	54
18" x 27"	2036-5	11	36	2036	12 <sup>1</sup> / <sub>4</sub>	36 <sup>3</sup> / <sub>16</sub>	19	31	62
23" x 34"	2037-5	11	36	2037	12 <sup>1</sup> / <sub>4</sub>	36 <sup>3</sup> / <sub>16</sub>	24	38	80
23" x 50"	2038-5	11	36	2038	12 <sup>1</sup> / <sub>4</sub>	36 <sup>3</sup> / <sub>16</sub>	24	54	98

*Better food service equipment — standard models and custom designs.*



- All arc welded stainless steel carts.
- Offered in two different styles and five different shelf sizes.
- 650# capacity.

**Style "A"**

All swivel casters (5" dia.)



Model 2165 (2 shelf)



Model 2164 (3 shelf)

**Style "B"**

Two swivel casters (5" dia.)  
and two load wheels (8" dia.)



Model 2167 (2 shelf)



Model 2166 (3 shelf)



**FEATURES:**

- **Uprites:** 1"x1"x1/8" (approx.) stainless steel angle
- **Shelves:** 18 GA. stainless steel, 3 edges up, front edge down.
- **Std. bumper:** Legs and push handle.
- **Casters:** Style "A"—All four swivel casters (5" dia.) Style "B"—Two (5" swivel) and two (8" fixed).

Shelf Size	Model #		Shelves		Overall Size (Inches) W-L-H	Approx. Shipping Weight (lbs.)
	Style "A"	Style "B"	No.	Space Between (Inches)		
16x24	2160	2162	3	10	17 <sup>3</sup> / <sub>8</sub> x30 <sup>3</sup> / <sub>8</sub> x34 <sup>1</sup> / <sub>2</sub>	59
	2161	2163	2	19	17 <sup>3</sup> / <sub>8</sub> x30 <sup>3</sup> / <sub>8</sub> x34 <sup>1</sup> / <sub>2</sub>	51
18x27	2164	2166	3	10	19 <sup>3</sup> / <sub>8</sub> x33 <sup>3</sup> / <sub>8</sub> x34 <sup>1</sup> / <sub>2</sub>	65
	2165	2167	2	19	19 <sup>3</sup> / <sub>8</sub> x33 <sup>3</sup> / <sub>8</sub> x34 <sup>1</sup> / <sub>2</sub>	55
21x33	2168	2170	3	11 <sup>3</sup> / <sub>8</sub>	22 <sup>3</sup> / <sub>8</sub> x39 <sup>3</sup> / <sub>8</sub> x37 <sup>3</sup> / <sub>8</sub>	81
	2169	2171	2	21"	22 <sup>3</sup> / <sub>8</sub> x39 <sup>3</sup> / <sub>8</sub> x37 <sup>3</sup> / <sub>8</sub>	67
21x50	2172	2174	3	11 <sup>3</sup> / <sub>8</sub>	22 <sup>3</sup> / <sub>8</sub> x56 <sup>3</sup> / <sub>8</sub> x37 <sup>3</sup> / <sub>8</sub>	106
	2173	2175	2	21	22 <sup>3</sup> / <sub>8</sub> x56 <sup>3</sup> / <sub>8</sub> x37 <sup>3</sup> / <sub>8</sub>	90
24x43	2176	2178	3	11 <sup>3</sup> / <sub>8</sub>	25 <sup>3</sup> / <sub>8</sub> x49 <sup>3</sup> / <sub>8</sub> x37 <sup>3</sup> / <sub>8</sub>	104
	2177	2179	2	21	25 <sup>3</sup> / <sub>8</sub> x49 <sup>3</sup> / <sub>8</sub> x37 <sup>3</sup> / <sub>8</sub>	88

- Option:** 1. Wrap around bumper 2. All edges up 3. Guard rail in front of each shelf.  
4. Polyurethane wheels & casters.  
5. 16 GA. shelves (up to 800# capacity).

*Better food service equipment — standard models and custom designs.*

- All welded stainless steel construction.
- Excellent for transporting / bussing trays and racks.
- Choice of two styles.

These units are ideal as general purpose utility carts and can carry 15"x20" or 16"x22" trays or various size tote boxes. 1" O.D. 16 GA. S/S tubing and heavy gauge polished S/S shelves with marine type raised edges and 5" swivel casters are standard.

**Style A: With Straight Uprights**

Offered in 1, 2, 3, 4 or 5 shelf models.

Model No.	No. of Shelves	Shelf Size (inches)	Height (Inches)	Shelf Clearance (inches)	Weight (Pounds)
2194-1	1	23x34	36 <sup>1</sup> / <sub>8</sub>	—	60
2194-2	2	23x34	36 <sup>1</sup> / <sub>8</sub>	20	68
2194-3	3	23x34	36 <sup>1</sup> / <sub>8</sub>	9	77
2194-4	4	23x34	45	8 <sup>1</sup> / <sub>2</sub>	98
2194-5	5	23x34	55	8 <sup>1</sup> / <sub>2</sub>	116



**Style "A"**  
1 Shelf Model  
2194-1



**Style "A"**  
2 Shelf Model  
2194-2



**Style "A"**  
3 Shelf Model  
2194-3



**Style "B"**  
2 Shelf Model  
2195-2



**Style "B"**  
3 Shelf Model  
2195-3



**Style B: With Formed Push Handles**

Offered in 2 or 3 shelf models.

Model No.	No. of Shelves	Shelf Size (inches)	Height (Inches)	Shelf Clearance (inches)	Weight (Pounds)
2195-2	2	23x34	35 <sup>3</sup> / <sub>4</sub>	18	68
2195-3	3	23x34	35 <sup>3</sup> / <sub>4</sub>	8 <sup>1</sup> / <sub>4</sub>	77

**Options:**

A. 5" Polyurethane casters. B. Round Bumpers.

*Better food service equipment — standard models and custom designs.*

**Deluxe Models, Heli-Arc welded & polished**

- Excellent quality cart for multi-purpose use in hotels, restaurants, cafeterias and hospitals. Can also be used as a dessert cart.
- 650# capacity.
- Available in two different styles, each with a choice of two or three shelves.
- N.S.F. listed.



- **Uprites:** 1 1/4" stainless steel tubing.
- **Casters:** 5"x1 1/4" deluxe (2 swivel, 2 rigid).
- **Shelves:** 18 GA. polished stainless steel, recessed (dished top) type.

**NOTE: These carts are also available with 1" dia. S/S tubing uprites and 5" stem casters. Add "-SM" after model number.**

Style	Shelf Size	Shelves			Overall Size (Inches) W - L - H	Shipping Weight (Inches)
		No.	Model #	SPACE BETWEEN (INCHES)		
Style "A"	23" x 34"	3	2196-3	11 3/4	24 1/4 x 38 1/4 x 34 1/2	64
		2	2196-2	25	24 1/4 x 38 1/4 x 34 1/2	48
	23" x 52"	3	2197-3	11 3/4	24 1/4 x 56 1/4 x 34 1/2	86
		2	2197-2	25	24 1/4 x 56 1/4 x 34 1/2	63
Style "B"	23" x 34"	3	2198-3	11 3/4	24 1/4 x 41 1/4 x 36 1/4	67
		2	2198-2	25	24 1/4 x 41 1/4 x 36 1/4	51
	23" x 52"	3	2199-3	11 3/4	24 1/4 x 59 1/4 x 36 1/4	89
		2	2199-2	25	24 1/4 x 59 1/4 x 36 1/4	66

- Options:** 1. All swivel casters. 2. Wrap around bumper. 3. Polyurethane casters (5")

**Heavy duty 3 shelf models with capacity up to 800# using 1 5/8" O.D. S/S tubing, 16 GA. S/S shelves and 5" polyurethane casters are available. Add "-HD" after these model numbers.**

Style "A"



Two Shelf  
Model 2196-2

Style "A"



Three Shelf  
Model 2196-3

Style "B"



Three Shelf  
Model 2198-3

*Better food service equipment — standard models and custom designs.*

**Deluxe Model, Heli-Arc Welded & Polished**

- **Ideal for hotel & restaurant kitchen service and hospitals.**
- **Easy access shelves.**
- **N.S.F. listed.**
- **Stays clean and sanitary with routine steam cleaning.**
- **Also meets Federal Specification KKK-T-1286A.**

This strong multi-purpose hand truck is a must around kitchens and food service areas.

The all welded stainless steel construction assures years of dependable service. A semi pneumatic non-marking vinyl bumper protects walls and other equipment.

The standard unit has dished type recessed shelves with all edges down in accordance with federal spec. KKK-T-1286A.

**Other features:**

- 18 GA. 304-No. 4 stainless steel shelves made with 1½" double folded edges recessed 3/8" and welded to 1¼" tubular frame.
- 1" tubular push handle.
- Two \*10" wheels and two 5" non-marking casters are standard.

\*If optional 8" load wheels are desired for economy, add "-8" after model number. However, if compliance to federal spec. KKK-T-1286A is required, 10" wheels must be used.



Model S-224-3SS



*Model Number	Shelves			Over All Size W-L-H	Shipping Wt.
	No.	Size	Space Between		
S-224-3SS	3	23 1/8 x 34 1/8	10	29x41 1/2 x 36 3/4	92#
S-224-2SS	2	23 3/8 x 34 1/8	21 1/2	29x41 1/2 x 36 3/4	77#

**Better food service equipment — standard models and custom designs.**

**Deluxe Models, 800 to 1,000# Capacity  
Heli/Wire Arc Welded & Polished**

**A. 800# Models:**

FEATURES:

- **Uprights:** 12 GA. S/S
- **Shelves:** 16 GA. S/S. All edges down or all edges up.
- **Casters:** 6" Polyurethane (2 swivel, 2 rigid)
- **Std. Bumper:** Legs & push handle.

Shelf Size	Model No.		Shelf Clearance (Inches)	Overall Size (Inches) L-W-H	Weight pounds
	Edges Down	Edges Up			
23" x 34"	2142-34	2142-U-34	11 ¼	38 ½ x 24 ½ x 36*	124
23" x 42"	2142-42	2142-U-42	11 ¼	46 ½ x 24 ½ x 36*	140
23" x 48"	2142-48	2142-U-48	11 ¼	52 ½ x 24 ½ x 36*	152



Model 2142-U-34  
all edges up) with optional  
8" pneumatic casters

**B. 1,000# Models:**

FEATURES:

- **Uprights:** 12 GA. S/S.
- **Shelves:** 14 GA. S/S. All edges down or all edges up.
- **Casters:** 8" deluxe polyurethane (2 swivel, 2 rigid)
- **Std. Bumpers:** Legs & push handle.

Shelf Size	Model No.		Shelf Clearance (Inches)	Overall Size (Inches) L-W-H	Weight pounds
	Edges Down	Edges Up			
25" x 35"	2143-35	2143-U-35	11 ¼	39 ½ x 26 ½ x 36*	138
25" x 42"	2143-42	2143-U-42	11 ¼	46 ½ x 26 ½ x 36*	150
27" x 54"	2143-54	2143-U-54	12	58 ½ x 28 ½ x 38 ¾*	166



Model 2143-42  
with all edges down

\*For models with edges up, add 1/4" to O.A. height. (Height shown is with 8" casters)

- Options:**
1. 8" polyurethane casters for 800# model. (Std. on 1,000# model)
  2. Balloon or pneumatic casters (8")
  3. Wrap around bumper.
  4. Two shelves only.
  5. All shelves (except bottom shelf) with 3 edges up, front edge down. Add "-RE" after model no.



*Better food service equipment — standard models and custom designs.*

**Deluxe Models 1,000# Capacity  
 Heli Arc Welded & Polished**

**A. Bent Leg Model**

**Features:**

- **Uprites:** 1-1/4"x1-1/4"x1/8" S/S angle. (approx.)
- **Shelves:** 14 GA. S/S double folded front & back to provide extra reinforcement, three edges up, front edge down.
- **Std. Bumper:** Legs & push handle.
- **Casters:** 2 - 5" deluxe swivel casters.  
 2 - 8" load wheels.

Shelf Size	Shelves			Overall Size (inch) W - L - H	Shipping Weight (lbs.)
	No.	Model #	Space Between		
24" x 34"	3	2040	11 3/8"	25 1/2 x 39 x 37 9/8"	112
	2	2041	21 1/2"	25 1/2 x 39 x 37 9/8"	92
24" x 43"	3	2043	11 3/8"	25 1/2 x 48 x 37 9/8"	128
	2	2044	21 1/2"	25 1/2 x 48 x 37 9/8"	103
25" x 35 1/2"	3	2047	10 3/4"	26 1/2 x 40 1/2 x 36 3/4"	152
	2	2048	22 5/8"	26 1/2 x 40 1/2 x 36 3/4"	123
24" x 48"	3	2153	11 3/8"	25 1/2 x 53 x 37 9/8"	183
	2	2154	21 1/2"	25 1/2 x 53 x 37 9/8"	145

- Options:** 1. Wrap around bumper.  
 2. 10" load wheels.



Model 2040

**B. Straight Leg Models**

**Features:**

- **Uprites:** 1 1/2" x 1 1/2" x 12 GA. S/S.
- **Shelves:** 14 GA. S/S recessed (dished top).
- **Clearance:** 11-7/16" between shelves.
- **Casters:** 8" deluxe, polyurethane.
- **Std. Bumper:** Legs & push handle.



Shelf Size	Model #	Overall Size (inch) L - W - H	Shipping Weight (lbs.)
23" x 34"	2045	39 x 24 1/2 x 35 7/8"	120
23" x 42"	2045-42	47 x 24 1/2 x 35 7/8"	134
23" x 52"	2045-52	47 x 24 1/2 x 35 7/8"	151



Model 2045  
 (with optional wrap around bumper)

*Better food service equipment — standard models and custom designs.*

- Heavy duty, multi purpose caddy for transporting and storing cups, saucers, glasses, dishes and trays.
- Choice of open top or with folding cover.
- Choice of one large single compartment or two smaller back to back compartments.

### Deluxe Large Single Compartment.

Model Number	Type	Capacity	O.A. Dimensions (Inches)	Weight (Pounds)
2192-300	Open Front	See below	26 x 40¾ x 41¼	148
2192-PD-300	Front with Folding Cover	See below	26 x 40¾ x 41¼	156

NOTE: Model 2192-PD-300 is offered with 3/16" or heavier reinforced LEXAN® glass folding cover with 16 ga. s/s hinges.

#### Capacity:

- A. Plates: Up to 300 (9" or 10" dia.) or 600 (7" dia.).
- B. Trays: Up to 160 trays 14" x 18" or 16" x 22".
- C. Cups/Glass Racks: 3 racks 10" x 20" carrying up to 120 cups or 216 glasses.
- D. Cups & Saucers: Up to 126 each in 20" x 20" racks.



**2192-300**  
(open front type)

**2192-PD-300**  
(with folding cover)

### Smaller Back to Back Double Compartments.

Model Number	Type	Capacity	O.A. Dimensions (Inches)	Weight (Pounds)
2191-2-324	Open Fronts	See below	24 x 36 x 36¼ H	128
2191-2-PD-324	Front & Back with Folding Covers	See below	24 x 36 x 36¼ H	136

NOTE: Model 2191-2-PD-324 is offered with 3/16" or heavier reinforced LEXAN® glass folding cover with 16 ga. s/s hinges.

#### Capacity:

- A. Plates: Up to 324 (9" or 10" dia.) or up to 432 (7" dia.) or up to 1,296 (5" dia.) approx. 54 plates/stack



**2191-2-324**  
(with optional round bumpers)

### Common Specifications:

- All stainless steel construction.
- 16 ga. polished stainless steel deck and bottom shelf with 1" O.D. x 16 ga. Polished s/s tubing frame push handles.
- S/S spacers between uprights and body allow for easy cleaning.
- Vinyl bumper at front and back are standard for 2192 Series.
- Undershelf for 2192 Series has raised marine type edge on all 4 sides and provides storage for empty boxes/racks.
- 5" heavy duty polyurethane casters are standard.

- Options:**
1. Round Bumpers
  2. Brakes on Casters
  3. Stainless steel folding cover instead of Lexan®.







# Deluxe bussing/pacemaker carts, standard, heavy duty and extra heavy duty, stainless steel

390-A Meyer Circle, Corona, California 92879-1078

Phone (951) 340-3419

Fax (951) 340-2716

## Deluxe Models, 500 to 1,000# capacity All welded and polished.

### A. 500# and 650# Models

FEATURES:

- **Shelves:** 20 GA S/S (for 500#), 18 GA. S/S (for 650#)
- **Sides & Back:** 20 GA S/S (for 500#), 18 GA. S/S (for 650#)
- **Std. Bumper:** Legs and push handle.
- **Casters:** 5" Deluxe (all swivel).

SHELF SIZE (INCHES)	NO. OF SHELVES	MODEL NUMBER		SHELF CLEARANCE (INCHES)	O.A. DIMENSIONS (INCHES)			WEIGHT (POUNDS)	
		500# CAPACITY	650# CAPACITY		WIDTH	LENGTH	HEIGHT	500# CAP.	650# CAP.
16x24	3	2006	2006-HD	12 <sup>3</sup> / <sub>8</sub>	18	28	36 <sup>3</sup> / <sub>16</sub>	53	59
	4	2006-4	2006-4-HD	9	18	28	40	63	69
18x27	3	2007	2007-HD	12 <sup>3</sup> / <sub>8</sub>	20	31	36 <sup>3</sup> / <sub>16</sub>	57	65
	4	2007-4	2007-4-HD	9 <sup>3</sup> / <sub>4</sub>	20	31	42 <sup>3</sup> / <sub>16</sub>	64	72
23x34	3	2008	2008-HD	12 <sup>3</sup> / <sub>8</sub>	25	38	36 <sup>3</sup> / <sub>16</sub>	96	107
	4	2008-4	2008-4-HD	9 <sup>3</sup> / <sub>4</sub>	25	38	42 <sup>3</sup> / <sub>16</sub>	106	125



3 Shelf Heavy Duty Model 2008-HD (shown with optional vinyl on 3 sides)



- Options: 1. Walnut grain vinyl on 3 sides. 2. 6" balloon casters. 3. Single front door. 4. Brakes on casters.

### B. 1,000# Models

FEATURES:

- **Shelves:** 14 GA. S/S
- **Sides & Back:** Heavy GA. S/S (reinforced)
- **Std. Bumper:** Wrap around & push handle.
- **Casters:** 8" Polyurethane (2 rigid, 2 swivel)
- **Reinforcement:** 1" x 1" x 1/8" S/S angles.

SHELF SIZE	NO. OF SHELVES	MODEL NUMBER	SHELF CLEARANCE (INCHES)	O.A. DIMENSIONS (INCHES)			WEIGHT (POUNDS)
				WIDTH	LENGTH	HEIGHT	
25x35	2	2008-2535-2-EHD	24 <sup>1</sup> / <sub>4</sub>	26 <sup>1</sup> / <sub>2</sub>	39 <sup>1</sup> / <sub>2</sub>	36	178
	3	2008-2535-3-EHD	11 <sup>3</sup> / <sub>8</sub>	26 <sup>1</sup> / <sub>2</sub>	39 <sup>1</sup> / <sub>2</sub>	36	202
25x42	2	2008-2542-2-EHD	24 <sup>1</sup> / <sub>4</sub>	26 <sup>1</sup> / <sub>2</sub>	46 <sup>1</sup> / <sub>2</sub>	36	195
	3	2008-2542-3-EHD	11 <sup>3</sup> / <sub>8</sub>	26 <sup>1</sup> / <sub>2</sub>	46 <sup>1</sup> / <sub>2</sub>	36	230



2 Shelf, Extra Heavy Duty Model 2008-2535-2-EHD

- Options: 1. Walnut grain vinyl on 3 sides. 2. 8" balloon casters. 3. Brakes on casters. 4. Double doors on front.

*Better food service equipment — standard models and custom designs.*

# Carts, transport & bussing, aluminum & stainless steel

## 2 Shelf Extra heavy duty cart, aluminum

- Ideal for transporting heavy loads (up to 1,500 lbs.)
- All welded construction.

Features:

- **Shelves:** 0.125" aluminum (all edges down). Bottom shelf reinforced with channels.
- **Uprites:** 1<sup>5</sup>/<sub>8</sub>" x 1<sup>5</sup>/<sub>8</sub>" x 1<sup>1</sup>/<sub>8</sub>" specially extruded angle
- **Braces:** 1<sup>1</sup>/<sub>2</sub>" x 1<sup>3</sup>/<sub>4</sub>" x 0.075" tubing.
- **Casters:** Six 8" polyurethane (4 swivel, 2 rigid)
- **Handle:** 1" alum. pipe



Model 1940-EHD-2445

Model No.	Shelf Size	Shelf Clearance (Inches)	O.A. Dimensions (inches)			Weight (pounds)
			Depth	Length	Height	
1940-EHD-2445	24 x 45	20	24 <sup>1</sup> / <sub>4</sub>	45 <sup>1</sup> / <sub>4</sub>	43	96
1940-EHD-2754	27 x 54	20	27 <sup>1</sup> / <sub>4</sub>	54 <sup>1</sup> / <sub>4</sub>	43	115

Options: A. Corner bumpers B. Wrap around bumper

## Stainless steel cart for trays, cups or glass racks

- All welded & polished S/S construction
- 1" S/S tubular uprites.
- Heavy gauge S/S shelf with die formed V (recessed) edges.
- 5" all swivel casters.

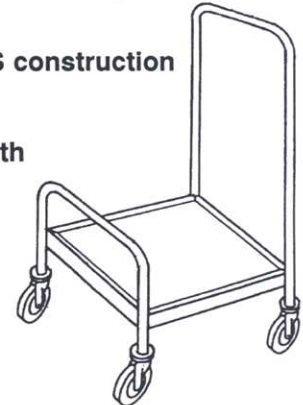

Model 2193-2020



Model No.	Type of Rack	Pan/Rack Size	O.A. Dimensions (inches)			Weight (pounds)
			Depth	Length	Height	
2193-2020	Single	20 x 20	24	24	35 <sup>3</sup> / <sub>4</sub>	46
2193-D-2020	Double	20 x 20	24	44	35 <sup>3</sup> / <sub>4</sub>	66
2193-D-1622	Double	*16 x 22	24	34	35 <sup>3</sup> / <sub>4</sub>	58

\*Will also carry single stack of 18" x 26" trays or double stack of 14" x 18" or 15" x 20" trays.

Options: A. 5" poly casters. B. Brakes on casters. C. Round bumpers on legs.

## Bussing cart for plastic lugs (12" x 20" & 15" x 20")

- Enclosed on three sides
- Choice of aluminum or stainless steel.
- 3 sided vinyl standard
- Furnished with 5" casters & wrap around bumper.
- Carries up to 10 lugs.
- 1" square tubing upper shelves with front stops to keep lugs in place.
- Bottom drain standard



Model 9001-1210-EN

Model Number		Lug size (inches)	Capacity	O.A. Dimensions (inches)			Weight (pounds)	
Aluminum	Stainless Steel			Depth	Length	Height	Alum.	S/S
9001-1210-EN	2001-1210-EN	12 x 21 x 6	10	25	41 <sup>3</sup> / <sub>4</sub>	56 <sup>1</sup> / <sub>4</sub>	99	160
9001-1510-EN	2001-1210-EN	15 x 20 x 5	10	25	47 <sup>3</sup> / <sub>4</sub>	56 <sup>1</sup> / <sub>4</sub>	120	192

Better food service equipment — standard models and custom designs.

## Deluxe, Heavy Duty Polished Stainless Steel Cart

**FEATURES:**

- **Bottom Shelf:** 14 GA. S/S
- **Top & Middle Shelf:** 18 GA. S/S (reinforced)
- **Body:** 18 GA. S/S
- **Doors:** 20 GA. S/S Double wall or 18 GA S/S single wall (reinforced)
- **Casters:** 6" H.D. Polyurethane (all swivel)
- **Bumper:** Wrap around.
- **Other:** Furnished with lockable latch.



2 Compartment Heavy Duty Stainless Steel  
 Model 2008-2-HD-3132-LL

Shelf Size	No. of Compartments	Model Number	Shelf Clearance (inches)	O.A. Dimensions (inches)			Weight (pounds)
				Width	Length	Height	
23 x 34	2	2008-2-HD-2334-LL	10½	26¾	36¾	48	220
	3	2008-3-HD-2334-LL	17	26¾	36¾	48	240
31 x 32½	2	2008-2-HD-3132-LL	10½	34¾	34¾	48	239
	3	2008-3-HD-3132-LL	17	34¾	34¾	48	259



Options: 1. Push Handle. 2. Brakes on casters.

## Standard Duty Aluminum Cart

**FEATURES:**

- **Shelves:** 0.063" alum.
- **Body:** 0.063" alum.
- **Door:** 0.080" alum (reinforced)
- **Casters:** 5" all swivel
- **Other:** Furnished with push handle & lockable latch

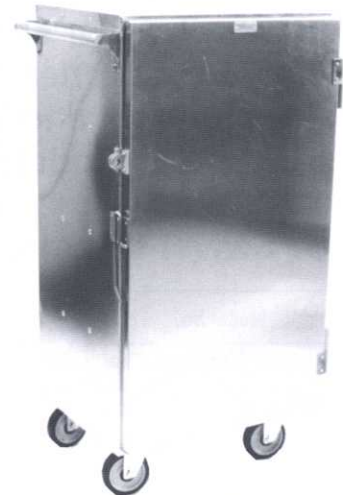
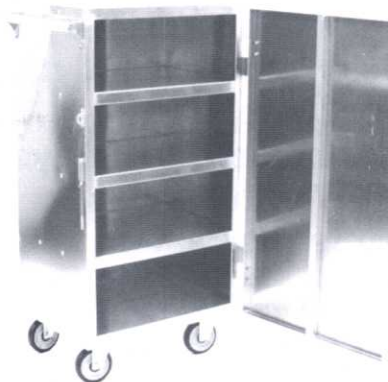

4 Compartment Aluminum  
 Model 9007-4-LL

SHELF SIZE	NO. OF COMPARTMENTS	MODEL NUMBER	SHELF CLEARANCE (INCHES)	O.A. DIMENSIONS (INCHES)			WEIGHT (POUNDS)
				WIDTH	LENGTH	HEIGHT	
18x27	3	9007-3-LL	11¾	20	31	47½	58
	4	9007-4-LL	8	20	31	47½	65
23x34	3	9008-3-LL	11¾	25	38	47½	74
	4	9008-4-LL	8	25	38	47½	79

**Options:**

1. Woodgrain vinyl on all sides.
2. Wrap around bumper.
3. Brakes on casters.

*Better food service equipment — standard models and custom designs.*

## Lug Carts

- Quick and easy transportation and storage of products in 16" x 25" x 8" lugs.
- Choice of aluminum or stainless steel all welded construction.
- 5" casters are standard.

Model No.		Capacity (No. of Lugs)	Shelf Clearance (inches)	Overall Dimensions (Inches)			Weight (Pounds)	
Aluminum	Stainless Steel			Width	Length	Height	Alum.	S/S
9567-1	9567-1-SS	1	—	16	24	19	11	16
9567-2	9567-2-SS	2	10	16	28	33	20	27
9567-3	9567-3-SS	3	10	19	27	41	27	34
9567-4	9567-4-SS	4	10	19	27	51	30	38
9567-6	9567-6-SS	6	10	19	27	71	33	42

Options: Pan stop for lugs.



Stainless Steel  
2 Lug Cart  
Model 9567-2-SS  
(shown with lug not included)

## Universal Cart



- Excellent multipurpose transporter with 1" square tubular shelf and frame construction.
- Ideal for bakeries, delis, produce and meat departments and for general use.
- Can accommodate various sizes of trays, lugs and pans up to 18" x 26".
- 5" Swivel steam casters (Heavy duty).

Model No.		Capacity (No. of Lugs)	Shelf Clearance (inches)	Overall Dimensions (Inches)			Weight (Pounds)	
Aluminum	Stainless Steel			Width	Length	Height	Alum.	S/S
9569-4	9569-4-SS	4	9 <sup>3</sup> / <sub>8</sub>	20 <sup>1</sup> / <sub>2</sub>	28	43 <sup>1</sup> / <sub>2</sub>	27	49
9569-5	9569-5-SS	5	8 <sup>3</sup> / <sub>4</sub>	20 <sup>1</sup> / <sub>2</sub>	28	50 <sup>3</sup> / <sub>4</sub>	31	57
9569-6	9569-6-SS	6	10 <sup>1</sup> / <sub>2</sub>	20 <sup>1</sup> / <sub>2</sub>	28	68 <sup>5</sup> / <sub>8</sub>	34	63
*9569-7	*9569-7-SS	7	8 <sup>3</sup> / <sub>4</sub>	28 <sup>3</sup> / <sub>4</sub>	32	68 <sup>5</sup> / <sub>8</sub>	62	115
**9569-5-EC	**9569-5-EC-SS	5	7 <sup>1</sup> / <sub>8</sub>	16 <sup>1</sup> / <sub>4</sub>	32	42 <sup>1</sup> / <sub>2</sub>	32	59
**9569-8-EC	**9569-8-EC-SS	8	7 <sup>1</sup> / <sub>8</sub>	16 <sup>1</sup> / <sub>4</sub>	32	68 <sup>1</sup> / <sub>4</sub>	43	78

\*This model is wider & longer. Each shelf can accommodate two 10" or 12" platters up to 30" long side by side.

\*\*These narrow width models are for platters and will not accommodate lugs.



Stainless Steel 7 Tier  
Model 9569-7-SS  
(lugs, trays, etc. not included)

Better food service equipment — standard models and custom designs.

### Extra heavy duty s/s delivery cart for insulated trays (style "A")

- Designed for thick insulated food trays.
- All welded s/s construction.
- 14 ga. s/s shelves with bottom shelf reinforced.
- 1" dia s/s tubular handle.
- 6"x 2" polyurethane casters (2 swivel, 2 rigid).
- Three sided 1½" s/s square tubing rail for top & bottom sections.



2147-2-2452  
(with optional bumper)



2147-2-3052-SD  
(with optional bumper & 6 casters)

Model Number	Shelf Size (Inches)	Shelf Clearance (Inches)	Tray Size (Inches)	*Tray capacity bottom shelf	O.A. Dimensions (Inches) W x L x H	Weight (Pounds)
2147-2-2436	24 x 36	27	11 x 16 x 2¾	36	24½ x 36¼ x 45	280
2147-2-2452	24 x 52	27	11 x 16 x 2¾	54	24¼ x 52¼ x 45	330
2147-2-2469	24 x 69	29	11 x 16 x 2¾	80	24¼ x 69¼ x 47	385
2147-2-3052	30 x 52	27	13⅞ x 15¼ x 2½	60	30¼ x 52¼ x 45	345
2147-2-3066	30 x 66	27	13⅞ x 15¼ x 2½	80	30¼ x 66¼ x 45	410

\*Tray capacity shown is for bottom shelf. Top shelf will accommodate 2 to 3 beverage containers plus additional trays depending upon shelf size.

**NOTE 1:** These carts are also available in aluminum construction. Add "-AL" after model number. Consult factory.

**NOTE 2:** Super heavy duty models are also available with additional reinforcement in top shelf, 1½" square tubing upright frame & 8"x 2" casters. Add "-SD" after model number.

#### Options

- A. 6 casters (4 swivel, 2 rigid) in lieu of 4 casters
- B. Vertical tray stops (2 on each end & up to 4 in the back) in bottom section

- C. Wrap around bumper
- D. 8" casters (polyurethane or balloon).

### Extra heavy duty s/s delivery cart for insulated trays (style "B")

- Designed for thick insulated food trays.
- All welded s/s construction.
- 14 ga. s/s shelves with bottom shelf reinforced.
- 1" dia s/s tubular handle.
- 6"x 2" polyurethane casters (2 swivel, 2 rigid).
- Provided with 8 slots (¾"x 3½") in top shelf & 6 slots in bottom shelf (larger model has 10 & 8) for tie down straps.



2145-2-2849

Model Number	Shelf Size (Inches)	Shelf Clearance (Inches)	Tray Size (Inches)	Tray Capacity	O.A. Dimensions (Inches) W x L x H	No. of Slots		Weight (Pounds)
						Top	Bottom Shelf	
2145-2-2849	28½ x 49½	33	13⅞ x 15¼ x 2½	Note 1	28¾ x 49¾ x 46½	10	6	320
2145-2-2865	28½ x 65¼	33	13⅞ x 15¼ x 2½	Note 2	28¾ x 65½ x 46½	12	8	425

**NOTE 1:** This model will carry 72 trays on bottom shelf & 24 to 32 trays plus two 5 gallon beverage containers or additional trays. Cart furnished with three (3) heavy duty tie-down straps with buckles.

**NOTE 2:** This model will carry 96 trays on bottom shelf & 28 to 40 trays plus three 5 gallon beverage containers or additional trays. Cart furnished with four (4) heavy duty tie-down straps with buckles.

#### Options

- A. Additional heavy duty tie-down straps with buckle
- B. Standard strap with buckle
- C. 8" casters (polyurethane or balloon).

*Better food service equipment — standard models and custom designs.*

# Heavy duty carts for insulated trays for correctional facilities

390-A Meyer Circle, Corona, California 92879-1078

Phone (951) 340-3419

Fax (951) 340-2716

## Heavy duty s/s delivery cart for insulated trays

- Designed for thick insulated food trays.
- 6" polyurethane casters (2 swivel, 2 rigid).
- 14 ga. s/s shelves with three edges up, front edge down.
- All welded s/s construction.
- 1" dia s/s tubular handle.
- 1 1/4"x1 1/4"x1/8" s/s angle uprights.

Model Number	Shelf Size (Inches)	Shelf Clearance (Inches)	Tray Size (Inches)	*Tray capacity bottom shelf	O.A. Dimensions (Inches) W x L x H	Weight (Pounds)
2041-2434	24 x 34	23	11 x 16 x 2 3/4	32	25 1/2 x 41 x 38 3/4	168
2041-2449	24 x 49	23	11 x 16 x 2 3/4	48	25 1/2 x 56 x 38 3/4	210
2041-2948	29 x 48	27	13 7/8 x 15 1/4 x 2 1/2	60	30 1/2 x 55 x 42 3/4	235
2041-2964	29 x 64	27	13 7/8 x 15 1/4 x 2 1/2	80	30 1/2 x 71 x 42 3/4	296

\*Tray capacity shown is for bottom shelf. Top shelf will accommodate 2 to 3 beverage containers plus additional trays depending upon shelf size.

### Options

Wrap around bumper

## 3 sides enclosed delivery cart for insulated trays, aluminum & stainless steel

- 14 ga. s/s or 0.125" thick alum. reinforced deck.
- 18 ga. s/s or 0.080" thick alum. body.
- 8"x 2" polyurethane casters (2 swivel, 2 rigid).
- Wrap around bumper & push handle.



2041-2434



S-5036-2-2449 (optional pneumatic casters)

Model Number		Shelf Size (Inches)	Shelf Clearance (Inches)	Tray Size (Inches)	Tray Capacity (see note)	O.A. Dimensions (Inches) W x L x H	Weight (Pounds)	
Alum	S/S						Alum	S/S
S-5036-2-2449	S-5100-2-2449	24 x 49	23	Duralux T-140 11x16x2 3/4	96	26 1/4 x 55 1/2 x 62 1/2	240	398
S-5036-2-2962	S-5100-2-2962	29 x 62	23	Alladin 13 7/8 x 15 1/4 x 2 1/2	144	31 1/4 x 68 1/2 x 62 1/2	276	442
**S-5036-2-2460	**S-5100-2-2460	24 x 60	23	Rock 9 1/2 x 14 1/4 x 1 3/4	192	26 1/4 x 66 1/2 x 62 1/2	262	438

NOTE: Tray capacity shown is the total capacity for two sections. Each section will carry one half the capacity shown.

Carts are also available with doors. Consult factory.

\*\*Can also carry 96 Plastocon (10 3/4" x 14 1/2" x 3 1/4") trays (48/section).



## Heavy duty s/s utility cart for correctional facilities

- 1,000# capacity.
- 14 ga. s/s reinforced shelves (3 edges up, front edge down).
- Heavy duty s/s uprights.
- 6"x 2" polyurethane casters (2 swivel, 2 rigid).

Shelf Size (Inches)	No. of Shelves	Model Number	Shelf Clearance (Inches)	O.A. Dimensions (Inches)			Weight (Pounds)
				W	L	H	
24 x 43	3	2143-RE-3-2443	13	24 1/4	43 1/4	40	125
	2	2143-RE-2-2443	22 1/2	24 1/4	43 1/4	35	106



2143-RE-3-2443

Better food service equipment — standard models and custom designs.

### Budget line dollies for 18"x26" bun pans & 20"x20" glass rack aluminum and stainless steel

- Material: Heavy wall aluminum or 14 GA. S/S.
- Casters: 5" all swivel.



Model-9086-BL-2020

Alum. Model No.	Stainless Steel Model No.	Pan/Rack Size	Type	O.A. Dim. (inches) WxLxH	Weight (Pounds)	
					Alum.	S/S
9086-BL-1826	2086-BL-1826	18x26	Single	18 <sup>3</sup> / <sub>8</sub> x26 <sup>3</sup> / <sub>8</sub> x8	20	26
9086-BL-D-1826	2086-BL-D-1826	18x26	Double	26 <sup>3</sup> / <sub>8</sub> x36 <sup>3</sup> / <sub>8</sub> x8	27	38
9086-BL-2020	2086-BL-2020	20x20	Single	20 <sup>1</sup> / <sub>2</sub> x20 <sup>1</sup> / <sub>2</sub> x8	19	25
9086-BL-D-2020	2086-BL-D-2020	20x20	Double	20 <sup>1</sup> / <sub>2</sub> x40 <sup>3</sup> / <sub>8</sub> x8	25	35

Option: Push Handle

### Budget line school lunch basket dollies, aluminum (with open corners)

- Material: 0.190" thick aluminum
- Casters: 5" all swivel.



Model-9085-BL-25  
(shown with wire baskets not furnished)

Model No.	Wire basket Size (Inches)	O.A. Dimensions (inches) WxLxH	Weight (Pounds)
9085-BL-25	13 <sup>3</sup> / <sub>8</sub> x25 <sup>3</sup> / <sub>8</sub> x2 <sup>5</sup> / <sub>8</sub>	26 <sup>1</sup> / <sub>2</sub> x27 <sup>3</sup> / <sub>8</sub> x8 <sup>1</sup> / <sub>4</sub>	21
9085-BL-20	13 <sup>3</sup> / <sub>8</sub> x20 <sup>3</sup> / <sub>8</sub> x2 <sup>5</sup> / <sub>8</sub>	21 <sup>1</sup> / <sub>2</sub> x27 <sup>3</sup> / <sub>8</sub> x8 <sup>1</sup> / <sub>4</sub>	19

Option: Push Handle

### Super duty glass rack dolly aluminum

- Material: .0125" thick hi-tensile aluminum
- Casters: 5"x1<sup>1</sup>/<sub>4</sub>" deluxe, all swivel.
- Posts: 2"x1"x<sup>1</sup>/<sub>8</sub>" alum. tube.
- Construction: All welded



Model 9085-SD-2020  
(shown with glass rack not furnished)

Model No.	Glass Rack (size)	O.A. Dimensions (inches) WxLxH	Weight (Pounds)
9085-SD-2020	20x20	20 <sup>5</sup> / <sub>8</sub> x20 <sup>5</sup> / <sub>8</sub> x11	18

Option: Push Handle



### Super duty dolly for school milk carton baskets, stainless steel

- Material: 12 GA. S/S
- Handles: 1" O.D. S/S tubing
- Casters: 5"x1<sup>1</sup>/<sub>4</sub>" deluxe, all swivel.
- Construction: All welded



Model 2086-D-1319  
(shown with baskets not furnished)

Model No.	Milk carton Basket size (inches)	O.A. Dimensions (inches) WxLxH	Weight (Pounds)
2086-D-1319	13 <sup>1</sup> / <sub>8</sub> x19 <sup>1</sup> / <sub>8</sub> x6 <sup>1</sup> / <sub>16</sub>	19 <sup>5</sup> / <sub>8</sub> x27 <sup>1</sup> / <sub>8</sub> x36 <sup>1</sup> / <sub>4</sub>	30

Better food service equipment — standard models and custom designs.

## Solid deck dolly

• Ideal for handlift cabinets and other packages and cartons.

- **Material:** 0.190" thick aluminum
- **Casters:** 5"x1 1/4" deluxe, all swivel



Model 9086-SB

## Dolly for 18"x26" bun pans and 20"x20" cup and glass racks

- **Material:** 0.190" thick aluminum
- **Casters:** 5"x1 1/4" deluxe, all swivel



Model 9086-1826



Model 9086-1826-HD-PH  
(with optional push handle & heavy duty side brace)

Model #	Edges	Width	Length	Height	Wt.
9086-SB	ALL DOWN	22"	30 1/8"	6 5/8"	20
9086-U-SB	ALL UP	22"	30 1/8"	7 5/8"	20

Model No.	Pan or Rack Size	Width	Length	Height	Wt.
9086-1826	18x26	18 3/8"	26 3/8"	8 1/4"	17
9086-2020	20x20	20 1/2"	20 1/2"	8 1/4"	18

**Option:** Stacking pins for handlift cabinets.

## Heavy duty dolly for school lunch baskets

- **Material:** 0.190" thick aluminum
- **Casters:** 5"x1 1/4" deluxe, all swivel

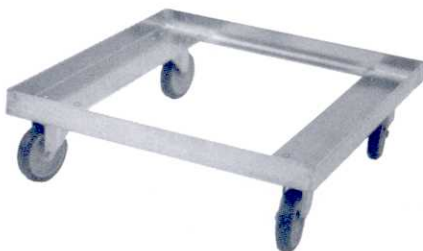

Model 9085-25  
Carries two wire baskets side by side.

## Extra heavy duty dolly for school lunch baskets

- **Material:** 1/4" thick aluminum frame
- **Casters:** 5" extra heavy duty (300# each), all swivel



Model 9085-HD-25  
Carries two wire baskets side by side.

Model #	Wire Basket Size	Width	Length	Height	Wt.
9085-25	13 3/8"Wx25 3/8"Dx2 3/8"H	26 1/2"	27 3/4"	8 1/4"	22
9085-20	13 3/8"Wx20 3/8"Dx2 3/8"H	21 1/2"	27 3/4"	8 1/4"	20

Model #	Wire Basket Size	Width	Length	Height	Wt.
9085-HD-25	13 3/8"Wx25 3/8"Dx2 3/8"H	26 3/4"	27 1/2"	8	28

*Better food service equipment — standard models and custom designs.*



- For 18''x26'' bun pans and 20''x20'' cup & glass racks.
- Choice of heavy duty or super duty models.

### HEAVY DUTY MODELS

- 14 GA. S/S frame.
- 5''x1¼'' deluxe, all swivel casters.

Model No.	Type of Rack	Pan/Rack Size	Overall Dimensions (Inches)			Weight (lbs.)
			Width	Length	Height	
2085-2020	Single	20x20	20½	20½	8¼	21
2085-D-2020	Double	20x20	20½	40½	8¼	25
2085-1826	Single	18x26	18¾	26¾	8¼	20
2085-D-1826	Double	18x26	26¾	36¾	8¼	24



Model 2085-1826

**Options:** Stainless steel tubular push handle.

### SUPER DUTY MODELS

- 12 GA. S/S frame with gussets.
- 5'' heavy duty casters, all swivel.

Model No.	Type of Rack	Pan/Rack Size	Overall Dimensions (Inches)			Weight (lbs.)
			Width	Length	Height	
2086-2020	Single	20x20	20½	20½	8¾	25
2086-D-2020	Double	20x20	20½	40¾	8¾	30
2086-1826	Single	18x26	18½	26½	8¾	24
2086-D-1826	Double	18x26	26½	36¾	8¾	29



Model 2086-D-2020  
Double glass rack  
shown with optional  
push handle.

**Options:** Stainless steel tubular push handle.

390-A Meyer Circle, Corona, California 92879-1078

Phone (951) 340-3419

Fax (951) 340-2716

## Stainless Steel

- Legs: 1"x1"x1/8" S/S Angle
- Capacity: 400 lbs.
- Construction: All welded
- Deck: 16 GA S/S.
- Casters: 5" all swivel



Model 2180-1  
(with optional leg bumpers)

Model #	Deck Size	Width	Length	Height	Wt.
2180-1	21"x33"	22 <sup>3</sup> / <sub>8</sub> "	37"	37 <sup>3</sup> / <sub>8</sub> "	46#

Option: A. 6" Casters.

B. Leg Bumpers

## Stainless Steel

- Handle: 1" O.D. S/S Tubing (fixed)
- Capacity: 650 lbs.
- Casters: 5" all swivel.



Model 2085-SB-PH-2030

Model #	Deck Size	Width	Length	Height	Wt.
2085-SB-PH-2030	20 <sup>3</sup> / <sub>8</sub> "x30"	21"	31 <sup>1</sup> / <sub>4</sub> "	36 <sup>1</sup> / <sub>2</sub> "	27#

Option: A. 6" Casters.

B. Removable Handle  
(in lieu of fixed)

## Aluminum

- Deck: 1<sup>1</sup>/<sub>2</sub>"x1<sup>3</sup>/<sub>4</sub>" x 0.075" alum. tube
- Handle: Removable 1" alum. pipe
- Casters: 5" all swivel.



Model 9090-M-PH-1842

Deck Size	Model No.	Weight (Pounds)
18x36	9090-M-PH-1836	22
18x42	9090-M-PH-1842	25
24x36	9090-M-PH-2436	34
24x48	9090-M-PH-2448	58

Option: A. Second push handle

B. 6" casters.



## Stainless steel

### Platform truck (semi-live skids)

- Deck: 12 GA. S/S
- Load Wheels: 8" (fixed)
- Construction: All welded with reinforced deck & heavy duty legs.
- Capacity: 2,000 lbs.



Model 6271-WH-3060-SS

Deck Size	Model No.	Weight (Pounds)
24x36	6271-WH-2436-SS	124
24x48	6271-WH-2448-SS	136
30x54	6271-WH-3054-SS	144
30x60	6271-WH-3060-SS	148
36x54	6271-WH-3654-SS	164
36x60	6271-WH-3660-SS	168

Better food service equipment — standard models and custom designs.

- High quality heavy duty dolly for storing, moving and dispensing dishes.
- Open from all 4 sides with flexibility of handling different size dishes including round and oval plates, platters and bowls.

This workhorse allows fast and efficient storage and movement of dishes from washer to dispensing areas. Stacks of dishes are held safely between uprights preventing spilling and breakage. Convenient height of majority of the models, wide track and compact design provide easy storage of dolly under most counters. Plastisol coating of uprights at points of contact prevent dishes from chipping, scratching and breakage.

Standard models are designed for specific size ranges. For greater flexibility, universal deluxe dollies, each with two adjustable adapters are offered which allow a large number of possible arrangements to mix and match various size dishes, bowls, plates and platters. 5"x1 1/4" deluxe, all swivel casters provide excellent maneuverability.

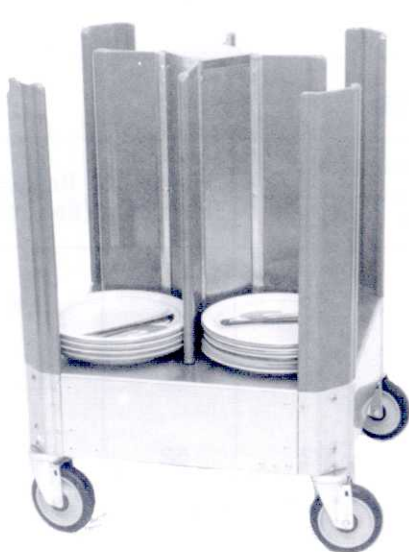

**Style A**

4 Compartments Standard Dolly  
Model 9601-1011-240



**Style B**

8 Compartments Standard Dolly  
Model 9601-57-480



**Style C**

4 Compartments Universal Deluxe Dolly  
Model 9601-DE-11 (comes standard  
with 2 adjustable adapters)

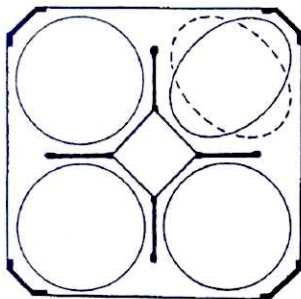

**STYLE "A"**

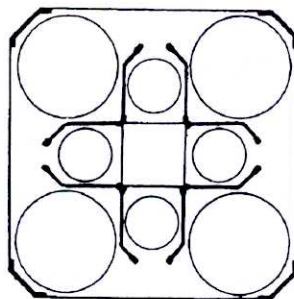

**STYLE "B"**

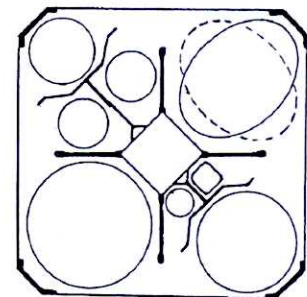

**STYLE "C"  
WITH TWO ADJUSTABLE  
ADAPTERS**



**For specifications, model numbers & options please see the back of this sheet.**

*Better food service equipment — standard models and custom designs.*

### Dish Dolly Specifications

- **Base:** 0.125" aluminum
- **Center Box Panels:** 0.125" aluminum
- **Corner Posts:** Specially extruded reinforced and wide angle shaped aluminum channel 45/8"x11/16" with wall thickness ranging from 0.105" to 0.500".
- **Dividers:** Specially extruded, reinforced and shaped aluminum bar 1/2"x51/8" with forked end.
- **Top Cap:** 0.063" aluminum
- **Points of Contact:** All points of contacts between corner posts and dividers are coated with approved Plastisol.
- **Caster Posts:** Reinforced 0.125" aluminum, double wall.
- **Casters:** 5"x1/14" deluxe, all swivel.

### Universal Deluxe Models (Furnished with two adjustable adapters)

Universal Deluxe Model	Approx Capacity	Plate/Dish Diameter (inches)	Style	Overall Dimension (inches)			Weight (Pounds)	Remarks (See notes)
				Width	Depth	Height		
9601-DE-11	Varies	4 <sup>1</sup> / <sub>8</sub> to 10 <sup>7</sup> / <sub>8</sub>	C	23	23	32	70	1,4
9601-DE-13	Varies	4 <sup>1</sup> / <sub>8</sub> to 12 <sup>3</sup> / <sub>4</sub>	C	27 <sup>1</sup> / <sub>2</sub>	27 <sup>1</sup> / <sub>2</sub>	32	80	1,4

### Standard Models (Adjustable Adapters are optional)

Model	Approx Capacity	Plate/Dish Diameter (inches)	Style	Overall Dimension (inches)			Weight (Pounds)	Remarks (See notes)
				Width	Depth	Height		
9601-68-240	240	6 <sup>7</sup> / <sub>8</sub> to 8 <sup>1</sup> / <sub>2</sub>	A	19	19	32	58	1,4
9601-89-240	240	8 <sup>5</sup> / <sub>8</sub> to 9 <sup>7</sup> / <sub>8</sub>	A	21	21	32	52	1,4
9601-46-480	480	4 <sup>7</sup> / <sub>8</sub> to 6 <sup>3</sup> / <sub>8</sub>	B	21	21	32	52	1,2
9601-57-480	480	5 <sup>1</sup> / <sub>2</sub> to 7 <sup>1</sup> / <sub>2</sub>	B	23	23	32	60	1,2
9601-1011-240	240	10 to 11 <sup>1</sup> / <sub>4</sub>	A	23	23	32	50	1,4
9601-1113-200	200	11 <sup>3</sup> / <sub>8</sub> to 13 <sup>1</sup> / <sub>8</sub>	A	27 <sup>1</sup> / <sub>2</sub>	27 <sup>1</sup> / <sub>2</sub>	32	76	1,4
9601-911-480	480	Banquet Rings	A	23	23	44	60	1,3

#### Notes:

1. Capacity varies based on weight, thickness, size and nesting of dishes and is shown here for reference only.
2. Larger dish size in style "B" will fit in the outer corner sections.
3. Banquet ring size used here varies from 9<sup>1</sup>/<sub>2</sub>" to 11<sup>1</sup>/<sub>8</sub>" in diameter.
4. For smaller size dishes (4" to 4<sup>3</sup>/<sub>4</sub>" ), use adapter kit. The largest dish size will vary.

#### Options:

1. Wrap around bumper.
2. Adjustable adapter.
3. Brakes on casters.
4. 5" polyurethane casters.
5. Vinyl dust cover.
6. Special color Plastisol.

- **An all purpose truck which takes the strain out of moving heavy loads around the kitchen, supply room and loading and unloading docks.**
- **Ideal for restaurants, hotels, hospitals and other sanitary places.**
- **2,000# capacity.**

This heavy duty platform truck saves time and increases efficiency. Indispensable around kitchen for moving all types of odd loads, including heavy stocks, food and equipment. Light hi-tensile aluminum construction makes it very easy to handle.

Shipped K-D. Just insert handle in the corner pockets and the unit is ready. No tools required. 2 rigid and 2 swivel 8" non-marking, NSF approved polyurethane casters with full perimeter bumper are standard. Manufactured in 5 platform sizes as shown.

Available to N.S.F. standards. Specify while ordering if N.S.F. compliance is required.

**Options:**

1. Brakes on swivel casters.
2. Fixed handle, add "-FH" after model number.
3. Mold on rubber wheels.
4. Balloon type cushion rubber wheels. (Reduces capacity to 1,800 pounds.)



PLATFORM TRUCK  
Model S-3752

CAPACITY: 2,000 lbs.

PLATFORM SIZE (INCHES)	MODEL #	
	ONE HANDLE	TWO HANDLES
24 X 48	S-3751	S-3751-2
27 X 54	S-3752	S-3752-2
30 X 60	S-3753	S-3753-2
36 X 60	S-3754	S-3754-2
36 X 72	S-3755	S-3755-2

- Excellent for moving heavy loads around kitchen.
- All stainless steel arc welded construction.
- Available in 1600# and 2,000# capacity models (3,600# optional)
- Choice of fixed rack handle or removable pipe handle
- N.S.F. listed.



Model 6275-SS  
Removable Pipe  
Handle type



Model 6271-SS  
Fixed rack handle type

**Specifications:**

**Deck:** 12 GA. S/S for 2,000# capacity truck, 14 GA. S/S for 1,600# capacity.

**Handle:** Fixed handle uprights are 1½" x 1½" x 3/16" s/s angles. Removable handle is 1" S/S pipe.

**Handle slats:** 1/8" x 2½" S/S flat bars.

**Casters:** 8" polyurethane for 2,000# capacity, 6" rubber for 1600# capacity (2 rigid, 2 swivel)

**Bumper:** Non marking wrap around bumper is standard on all models.



Capacity	Platform Size (Inches)	Model Number		Weight
		Fixed Handle	Removable Handle	
1,600#	27x54	6251-16-SS	6255-16-SS	122
	24x48	6231-SS	6235-SS	110
2,000#	27x54	6251-SS	6255-SS	136
	30x60	6271-SS	6275-SS	151
	36x72	6281-SS	6285-SS	183

**Options:**

- A. Extra Handle with slats
- B. Balloon type cushion rubber wheels (reduces capacity to 1,800#)
- C. 3,600# capacity
- D. Brakes on swivel casters

**Correctional Package available. Consult factory.**

*Better food service equipment — standard models and custom designs.*